

# ISUZU

## SPECIFICATIONS

### NQR 87/80-190

### NQR 87/80-190 CREW



NQR 87/80-190 Crew



NQR 87/80-190

AUSTRALIA'S TOP SELLING TRUCK BRAND SINCE 1989.

#### AT A GLANCE

GVM	8,700 / 8,000 kg
GCM	12,200 / 11,500 kg
Power	140 kW @ 2,600 rpm
Torque	513 Nm @ 1,600 - 2,600 rpm

#### OPTIONS

**Automated Manual Transmission (AMT) model:** includes AMT

**Access Hatch (AH) model:** includes AMT / fixed cab mounting with hatch for engine access

#### ADVANCED TECHNOLOGY

Emissions: Euro V / ADR 80/03  
Driver and passenger airbag with seatbelt pretensioner  
ECE-R29 compliant cab  
Anti-lock Braking System (ABS)  
Stability Control System (IESC)  
Anti Skid Regulator (ASR)

Hill Assist - except with AMT  
Electric mirrors  
Cruise control  
Front and rear stabiliser bars  
Driver suspension seat - except crew and AH models  
Cornering lamps



# ISUZU TRUCKS

# NQR 87/80-190

## NQR 87/80-190 CREW

### DRIVELINE AND CHASSIS SPECIFICATIONS

#### ENGINE: ISUZU 4HK1-TCC

**Type:** 4 cylinder 16 valve SOHC  
**Displacement:** 5,193 cc  
**Compression ratio:** 17.5:1  
**Bore x Stroke:** 115 mm x 125 mm  
**Max power (DIN - NET):** 140 kW (188 HP) @ 2,600 RPM  
(JIS Gross): 145 kW (194 HP) @ 2,600 RPM  
**Max torque (DIN - NET):** 513 Nm (378 lb.ft) @ 1,600 - 2,600 RPM  
(JIS Gross): 531 Nm (392 lb.ft) @ 1,600 - 2,600 RPM  
**Induction system:** Electronically controlled variable nozzle turbocharger with air-to-air intercooler.  
**Fuel injection:** Direct injection high pressure common rail system.  
**Emission control system:** Cooled EGR with exhaust Diesel Oxidation Catalyst (DOC). ADR 80/03 (Euro V) compliant.

#### CLUTCH

##### Standard model:

- Auto adjusting hydraulic control with vacuum assistance. Single plate 325 mm diameter.
- Total lining area: 966 cm<sup>2</sup>

##### With AMT:

- Fully automated hydraulically controlled wet clutch and fluid coupling with lock up.

#### TRANSMISSION

##### Isuzu MZZ-6F

- PTO provision on LHS of transmission case. PTO drive from counter gear.
- Gear ratios (: 1)

1st	2nd	3rd	4th	5th	6th	Rev
6.369	3.767	1.966	1.355	1.000	0.782	6.369

##### Standard model:

- 6 speed manual. Synchromesh on gears 1-6.

##### With AMT:

- 6 speed Automated Manual Transmission (AMT) with both fully automatic and clutchless manual operation modes.

#### AXLES

##### Front: Isuzu F031

- Reverse Elliot I-beam. 3,100 kg capacity.

##### Rear: Isuzu R066

- Full floating Banjo type. Four differential pinions. 6,600 kg capacity.
- Drive ratio: 4.100:1 (Standard model), 4.300:1 (with AMT)

#### SUSPENSION

##### Front:

- **Single cab:** Single stage alloy steel taper leaf springs.
- **Crew cab:** Single stage alloy steel multi leaf springs.
- Double acting hydraulic shock absorbers. Stabiliser bar.

##### Rear:

- Multi leaf main spring, multi leaf helper spring.
- Double acting hydraulic shock absorbers. Stabiliser bar.

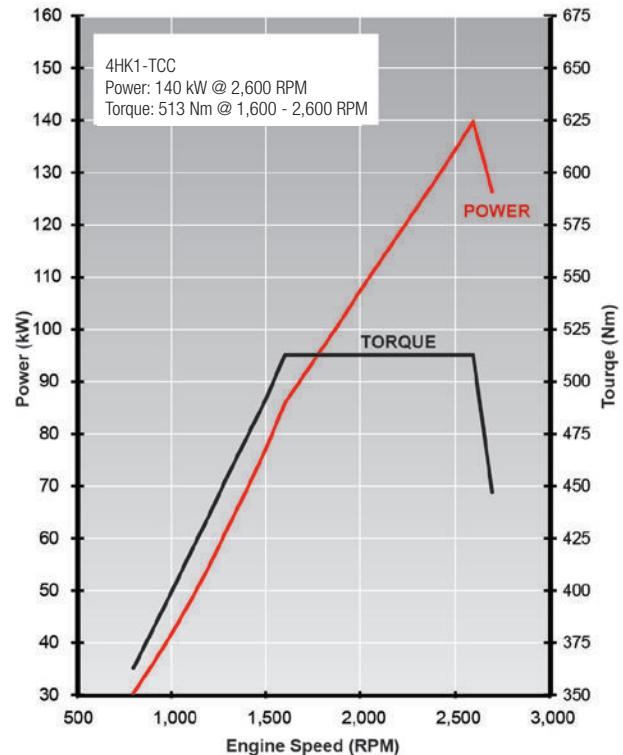

#### BRAKES

- Auto adjusting front and rear disc brakes with dual circuit hydraulic control, integrated boost assist and electronic brake force distribution (EBD).
- ABS, ASR traction control.
- IESC stability control.
- Hill Assist - except with AMT.
- Front disc diameter: 363 mm.
- Rear disc diameter: 348mm.
- Vacuum controlled exhaust brake.
- 203mm diameter drum park brake mounted on rear of transmission.

#### STEERING

- Power assisted recirculating ball steering.
- Gear ratio: 20.9:1
- Turns lock to lock: 5.4
- Maximum angle: 43° (inside wheel) / 33° (outside wheel)

#### WHEELS AND TYRES

- 19.5 x 6.00 six stud steel wheels.
- 225/70R 19.5 125/123L Michelin XZE Tubeless.
- Maximum tyre rating:
  - Steer axle: 3,300 kg
  - Drive axle: 6,200 kg
- 1 frame mounted spare wheel and tyre assembly.

#### CHASSIS FRAME

- Cold rivetted ladder frame. SAPH440 weldable steel sidemembers. Parallel side rails and rivetless top flange.
- Frame dimensions:
  - Side rail (mm): 216 x 70 x 6.0
  - Rear frame width (mm): 850

## FUEL TANK

- Frame mounted 140L steel fuel tank.
- Lockable fuel cap.

## ELECTRICAL SYSTEM

- 24 volt electrical system.
- 90 amp alternator.
- 4.5 kW starter motor.
- 2 x 80D26L (630 CCA) batteries connected in series.

## CABIN SPECIFICATIONS AND APPOINTMENTS

### CAB EXTERIOR

- All steel construction. High tensile steel used for cab underframe.  
**Single cab:** Manual cab tilt to 45° with torsion bar assistance.  
**Crew cab / AH model:** Fixed cab mounting.
- Complies with ECE-R29 cab strength standard.
- **Single cab:** Liquid filled front and rear cab mounts.  
**Crew cab / AH model:** Rubber cab mounts.
- Heavy duty non slip entry steps.
- 90° opening internally reinforced front doors.
- Water spray suppression guards and front mudflaps.
- Laminated windscreen with shade band.
- Two speed windscreen wipers with intermittent wipe mode.
- Halogen multi-reflector headlamps incorporating turn signals. Additional door mounted integrated side indicator/cornering lamps.
- Combination brake, turn, reverse and marker lamps, registration plate illumination lamps. Extended wiring harness. Reverse alarm.
- Roof-mounted clearance lamps.
- Heated and powered exterior main mirrors with flat glass and additional independently adjustable convex “spot” mirrors.
- Chrome grille.
- Body coloured impact resisting polycarbonate bumper with steel backing frame. Includes front foglamps.

### CAB INTERIOR

- Contoured adjustable driver’s bucket seat. **Single cab except AH model:** includes mechanical suspension rated to 130kg
- Front passenger bench seat with 2 seat capacity.
- **Crew cab / AH:** Engine access provided under removable driver seat base and tiltable front passenger seat.
- **Crew cab:** Rear bench seat with 4 seat capacity.
- 3-point lap sash seatbelts in all outboard seating positions. Driver and outboard front passenger seatbelts fitted with pretensioner. Centre seat lap belts.
- Driver and outboard front passenger airbag.
- **With AMT:** Driver’s footrest.
- Door and roof pillar entry assist grips. **Crew cab:** Full width rear grab rail with ashtray.
- Full interior trim, padded roof lining and vinyl floor covering. Driver and passenger windscreen header storage shelf.
- Tilt/Telescopic adjustable steering column, soft feel urethane steering wheel.
- Electric windows.
- Central locking with remote keyless entry and immobiliser.
- Twin cup holders. 24V cigarette lighter. Dashboard hook.
- Front door mounted storage pockets and driver’s side ashtray.
- Centre console box with storage tray. Fold down storage tray behind centre seat backrest.
- Fully integrated auto control air conditioning and heater/demister with 4-speed fan and outlets for windscreen, side windows, face and floor.
- Interior lamp with On/Door/Off switch.  
**Single cab:** fluorescent type. **Crew cab:** standard type.

- 2 DIN, two speaker multimedia unit with 6.2” LCD capacitive touch screen. 1.6GHz processor with Android operating system. DAB+ digital radio and fully integrated Bluetooth with voice recognition. Inbuilt PDF, photo and movie viewer. Internet radio accessible via smartphone. 32GB internal file storage. USB and auxilliary input connection provisions. Firmware and map updates possible via smartphone.
- DIN sized compartment for storage or for CB radio installation.

### DRIVER CONTROLS

- Key-operated engine start/stop and steering lock. Engine idle speed control.
- Hill Assist slow/fast engagement control and on/off switch - except with AMT.
- ASR and IESC on/off.
- **With AMT:** AMT slow/fast gear engagement control, 1st gear start and normal/economy gear selection modes.
- **With AMT:** Gear selection control with R-N-D and sequential shift positions.
- **Left side combination stalk:** Windscreen wipers, washers and exhaust brake.
- **Right side combination stalk:** Turn signals, headlamps, cruise control.

### INSTRUMENTATION

- Electronically driven speedometer and tachometer. Digital odometer with integrated dual tripmeter. Engine coolant temperature and fuel level gauges.
- **Warning lamps:** Check engine, oil pressure, ABS, SRS airbag, alternator charge, service brakes, park brake, seat belt unfastened, low fuel level.  
**With AMT:** Check AMT.
- **Indicator lamps:** Hill Assist (except with AMT), warm up system, high beam, ASR, IESC, exhaust brake, turn signals, cruise control.  
**With AMT:** econo-mode, 1st gear start
- **With AMT:** Gear selection display.
- **Multi information display:** Shows service interval, instantaneous and average fuel consumption, hourmeter, voltmeter, time/day/date and includes 40-120 km/h adjustable vehicle speed warning.

### OPTIONS AND GENUINE ACCESSORIES

Include the following (extra cost, request a brochure and further details from your Isuzu dealer):

#### Multimedia unit:

- Isuzu satellite navigation including 3 years of free updates.
- Supports up to five camera inputs. One low light capable digital camera and rear microphone input active when reversing. Four analogue cameras.
- Reversing sensors.
- Tyre pressure monitoring system.

#### Other:

- Airbag compatible bullbar.
- 3,500 kg rated towbar.
- Air deflector.

## ISUZU CARE

Isuzu Care gives truck owners access to products and services including Roadside Assist, Service Agreements, Extended Care, Extended Isuzu Assist and the Isuzu Care Centre. Call 1800 035 640.

### WEIGHTS (kg)

Models	Ratings*		Loading Limit* (at ground)		Cab Chassis Weight #		
	GVM	GCM	Front	Rear	Front	Rear	Total
NQR 87/80-190 MWB	8,700 / 8,000	12,200 / 11,500	3,100	6,200	1,840	1,010	2,850
NQR 87/80-190 AMT MWB	8,700 / 8,000	12,200 / 11,500	3,100	6,200	1,840	1,010	2,850
NQR 87/80-190 AMT MLWB	8,700/8,000	12,200 / 11,500	3,100	6,200	1,855	1,000	2,855
NQR 87/80-190 LWB	8,700 / 8,000	12,200 / 11,500	3,100	6,200	1,910	1,030	2,940
NQR 87/80-190 AMT LWB	8,700 / 8,000	12,200 / 11,500	3,100	6,200	1,910	1,030	2,940
NQR 87/80-190 AMT LWB AH	8,700 / 8,000	12,200 / 11,500	3,100	6,200	1,930	1,045	2,975
NQR 87/80-190 CREW	8,700 / 8,000	12,200 / 11,500	3,100	6,200	2,070	1,060	3,130
NQR 87/80-190 AMT CREW	8,700 / 8,000	12,200 / 11,500	3,100	6,200	2,070	1,060	3,130

\* Vehicle ratings and front/rear weight limits are subject to government regulatory requirements and weight distribution analysis. Consult your Isuzu dealer to select the correct vehicle for your specific application. # Cab chassis only as supplied and including 10 litres of fuel.

### DIMENSIONS (mm)

Models	WB	OAL	FOH	ROH	EA	CE	RT	ORT	CH	FFA (unladen)	RFA (unladen)	RFH (unladen)	Turn Circle (m)
													KERB TO KERB
NQR 87/80-190 MWB	3,365	5,985	1,110	1,510	2,680	4,302	1,670	2,150	2,310	710	815	855	12.4
NQR 87/80-190 MLWB	3,815	6,630	1,110	1,705	3,130	4,947	1,670	2,150	2,310	710	810	850	14.0
NQR 87/80-190 LWB	4,475	7,804	1,110	2,219	3,790	6,121	1,670	2,150	2,310	710	815	865	16.4
NQR 87/80-190 CREW	4,475	7,804	1,110	2,219	2,810	5,120	1,670	2,150	2,310	700	820	875	16.4

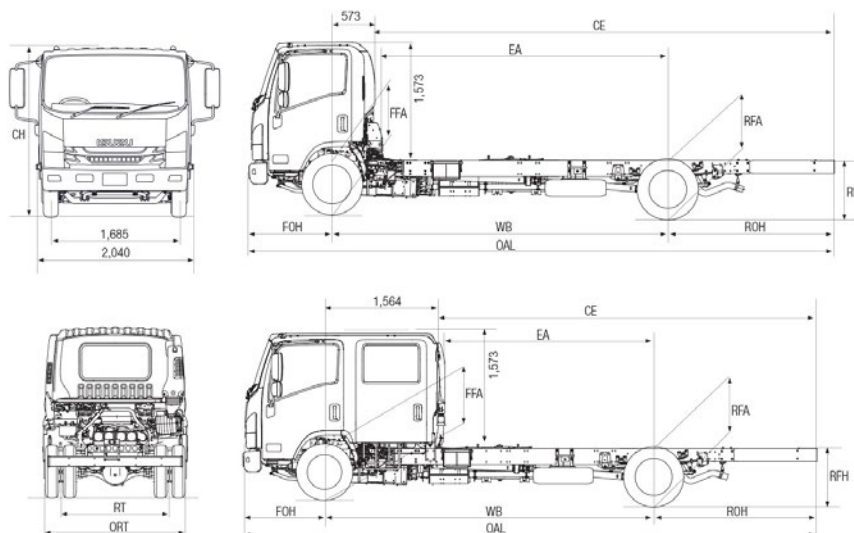

### PERFORMANCE (calculated - typical paved road)

		Geared Speed* (top gear at peak power engine RPM)	Low Speed Gradeability (lowest forward gear assuming no wheel slip)	Engine Speed (top gear at 100km/h)
NQR 80-190	At 8,000 kg GVM	121 km/h @ 2,600 RPM	38%	2,145 RPM
NQR 87-190	At 8,700 kg GVM	121 km/h @ 2,600 RPM	35%	2,145 RPM
NQR 80-190 AMT	At 8,000 kg GVM	116 km/h @ 2,600 RPM	40%	2,245 RPM
NQR 87-190 AMT	At 8,700kg GVM	116 km/h @ 2,600 RPM	37%	2,245 RPM

\*Maximum speed achievable depends on vehicle frontal area as well as other factors. Consult your Isuzu dealer for more detailed information.

### ISUZU WARRANTIES

STANDARD <sup>1</sup>	
New Vehicle	3 years • 100,000km • 2,000 hours
Cab Perforation Corrosion	3 years • Unlimited km
Isuzu Assist: 24 hour roadside assistance (3 years, unlimited km)*	
EXTENDED CARE <sup>2</sup>	
Extended Warranty: 5 years • 250,000km • 4,500 hours	
Isuzu Assist: 24 hour roadside assistance (5 years, unlimited km)	

### ORDER CODES

Model	Code
NQR 87/80-190 MWB	NH-NQRAC-B18
NQR 87/80-190 AMT MWB	NH-NQRAC-D18
NQR 87/80-190 AMT MLWB	NH-NQRAC-K18
NQR 87/80-190 LWB	NH-NQRAC-C18
NQR 87/80-190 AMT LWB	NH-NQRAC-E18

Model	Code
NQR 87/80-190 AMT LWB AH	NH-NQREC-T18
NQR 87/80-190 CREW	NH-NQRCC-C18
NQR 87/80-190 AMT CREW	NH-NQRCC-E18

<sup>1</sup> Subject to the conditions outlined in the IAL New Vehicle Warranty, the Isuzu NQR models carry a standard factory warranty which covers the owner: (i) for the entire vehicle, for the first 36 months or 100,000 km or 2,000 hrs (whichever comes first), (ii) against cab perforation corrosion, for 36 months and unlimited kilometres. <sup>2</sup> Extended Warranty as illustrated may be purchased to cover the owner against the failure of original components, but may exclude some components and expendable items such as oil, filters, etc. \*Valid for three years from the date of new vehicle purchases. All Isuzu warranties are subject to mandatory prescribed terms under Australian Consumer law including customer guarantees. For more details visit the Isuzu website which explains Isuzu warranties in more detail, or alternatively contact your local dealer. All warranties commence from date of delivery.

ISUZU AUSTRALIA LIMITED ABN 97 006 962 572 ("IAL"). The information in this spec sheet was correct at time of printing, but all measurements, specifications and equipment are subject to change without notice. Some equipment may have been changed and/or is available at extra cost. IAL may make changes at any time without notice, in prices, colours, materials, equipment and models. IAL makes all reasonable attempts to ensure the availability of all vehicles and equipment. The information in this spec sheet is general in nature. Your Isuzu dealer can confirm all measurements, specifications and vehicle / equipment availability upon request. To the extent permitted by the law, IAL is not liable to any person as result of reliance on the content of this spec sheet.